

# APPENDIX B - OSHA SAFETY STANDARDS FOR STEEL ERECTION

## BAY LENGTH DEFINITIONS

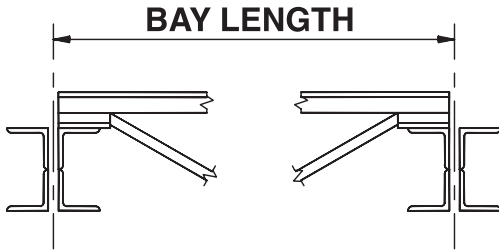

JOIST GIRDERS

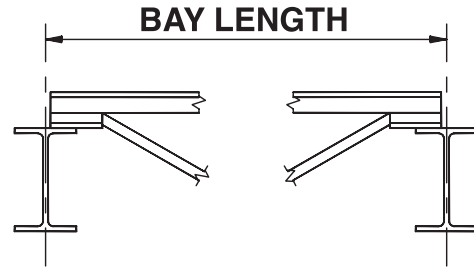

STEEL BEAM

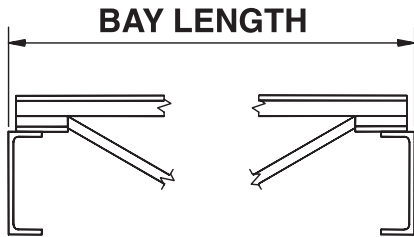

STEEL CHANNEL

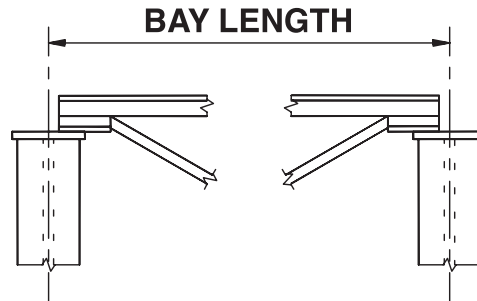

STEEL COLUMN

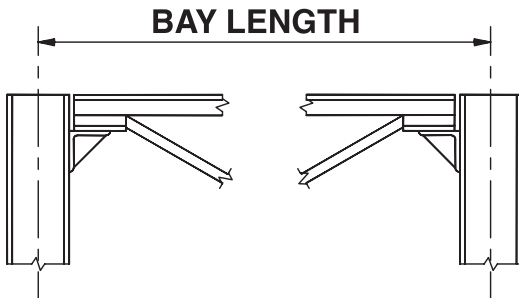

STEEL COLUMN

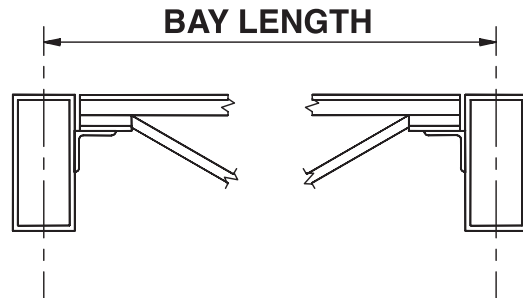

STEEL TUBE



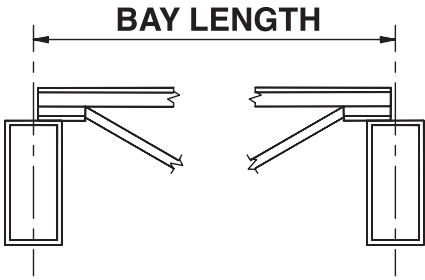

**STEEL TUBE**

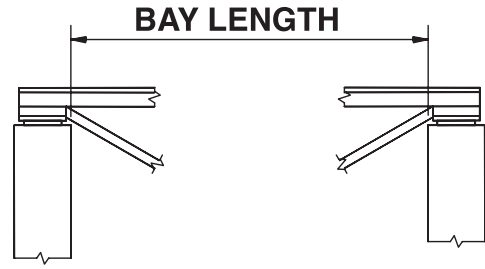

**MASONRY OR TILT-UP**

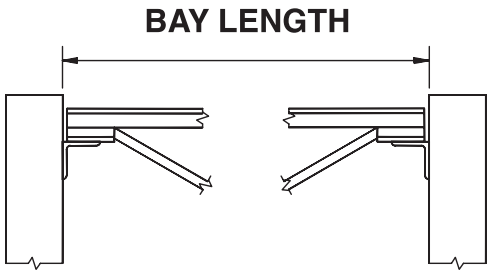

**MASONRY OR TILT-UP**

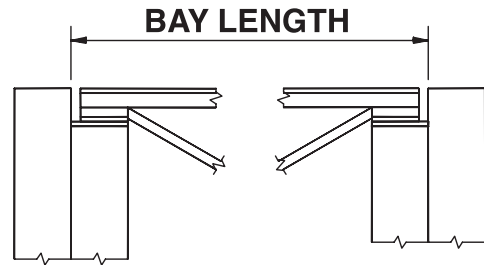

**MASONRY WITH PILASTER**

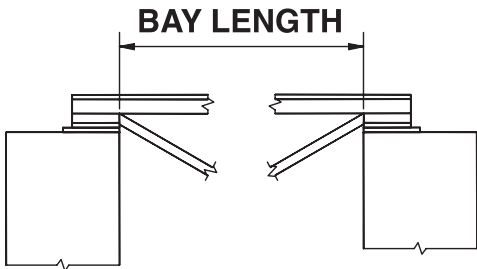

**MASONRY OR TILT-UP**

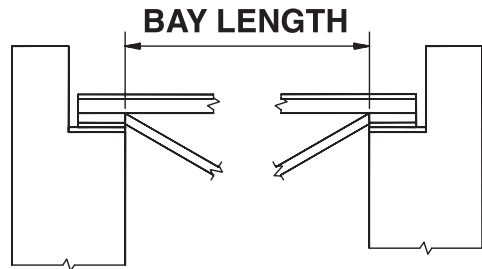

**MASONRY OR TILT-UP**

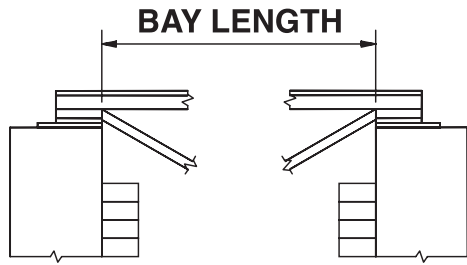

**MASONRY WITH FACE BRICK**



## §1926.751 DEFINITIONS

(Selected items only)

Anchored bridging means that the steel joist bridging is connected to a bridging terminus point.

Bolted diagonal bridging means diagonal bridging that is bolted to a steel joist or joists.

Bridging clip means a device that is attached to the steel joist to allow the bolting of the bridging to the steel joist.

Bridging terminus point means a wall, a beam, tandem joists (with all bridging installed and a horizontal truss in the plane of the top chord) or other element at an end or intermediate point(s) of a line of bridging that provides an anchor point for the steel joist bridging.

Column means a load-carrying vertical member that is part of the primary skeletal framing system. Columns do not include posts.

Constructibility means the ability to erect structural steel members in accordance with subpart R without having to alter the over-all structural design.

Construction load (for joist erection) means any load other than the weight of the employee(s), the joists and the bridging bundle.

Erection bridging means the bolted diagonal bridging that is required to be installed prior to releasing the hoisting cables from the steel joists.

Personal fall arrest system means a system used to arrest an employee in a fall from a working level. A personal fall arrest system consists of an anchorage, connectors, a body harness and may include a lanyard, deceleration device, life-line, or suitable combination of these. The use of a body belt for fall arrest is prohibited.

Project structural engineer means the registered, licensed professional responsible for the design of structural steel framing and whose seal appears on the structural contract documents.

Qualified person (also defined in § 1926.32) means one who, by possession of a recognized degree, certificate, or professional standing, or who by extensive knowledge, training, and experience, has successfully demonstrated the ability to solve or resolve problems relating to the subject matter, the work, or the project.

Steel joist means an open web, secondary load-carrying member of 144 feet (43.9 m) or less, designed by the manufacturer, used for the support of floors and roofs. This does not include structural steel trusses or cold-formed joists.

Steel joist girder means an open web, primary load-carrying member, designed by the manufacturer, used for the support of floors and roofs. This does not include structural steel trusses.

Structural steel means a steel member, or a member made of a substitute material (such as, but not limited to, fiberglass, aluminum or composite members). These members include, but are not limited to, steel joists, joist girders, purlins, columns, beams, trusses, splices, seats, metal decking, girts, and all bridging, and cold formed metal framing which is integrated with the structural steel framing of a building.

## §1926.757 OPEN WEB STEEL JOISTS

### (a) General.

(1) Except as provided in paragraph (a)(2) of this section, where steel joists are used and columns are not framed in at least two directions with solid web structural steel members, a steel joist shall be field-bolted at the column to provide lateral stability to the column during erection. For the installation of this joist:

- (i) A vertical stabilizer plate shall be provided on each column for steel joists. The plate shall be a minimum of 6 inch by 6 inch (152 mm by 152 mm) and shall extend at least 3 inches (76 mm) below the bottom chord of the joist with a 13/16 inch (21 mm) hole to provide an attachment point for guying or plumbing cables.
- (ii) The bottom chords of steel joists at columns shall be stabilized to prevent rotation during erection.
- (iii) Hoisting cables shall not be released until the seat at each end of the steel joist is field-bolted, and each end of the bottom chord is restrained by the column stabilizer plate.

(2) Where constructibility does not allow a steel joist to be installed at the column:

- (i) an alternate means of stabilizing joists shall be installed on both sides near the column and shall:
  - (A) provide stability equivalent to paragraph (a)(1) of this section;
  - (B) be designed by a qualified person;
  - (C) be shop installed; and
  - (D) be included in the erection drawings.
- (ii) hoisting cables shall not be released until the seat at each end of the steel joist is field-bolted and the joist is stabilized.

(3) Where steel joists at or near columns span 60 feet (18.3 m) or less, the joist shall be designed with sufficient strength to allow one employee to release the hoisting cable without the need for erection bridging.

(4) Where steel joists at or near columns span more than 60 feet (18.3 m), the joists shall be set in tandem with all bridging installed unless an alternative method of erection, which provides equivalent stability to the steel joist, is designed by a qualified person and is included in the site-specific erection plan.



(5) A steel joist or steel joist girder shall not be placed on any support structure unless such structure is stabilized.

(6) When steel joist(s) are landed on a structure, they shall be secured to prevent unintentional displacement prior to installation.

(7) No modification that affects the strength of a steel joist or steel joist girder shall be made without the approval of the project structural engineer of record.

(8) *Field-bolted joists.*

(i) Except for steel joists that have been pre-assembled into panels, connections of individual steel joists to steel structures in bays of 40 feet (12.2 m) or more shall be fabricated to allow for field bolting during erection.

(ii) These connections shall be field-bolted unless constructibility does not allow.

(9) Steel joists and steel joist girders shall not be used as anchorage points for a fall arrest system unless written approval to do so is obtained from a qualified person.

(10) A bridging terminus point shall be established before bridging is installed. (See Appendix C to this subpart.)

**(b) Attachment of steel joists and steel joist girders.**

(1) Each end of “K” series steel joists shall be attached to the support structure with a minimum of two 1 /8 -inch (3 mm) fillet welds 1 inch (25 mm) long or with two 1 /2 -inch (13 mm) bolts, or the equivalent.

(2) Each end of “LH” and “DLH” series steel joists and steel joist girders shall be attached to the support structure with a minimum of two 1 /4 -inch (6 mm) fillet welds 2 inches (51 mm) long, or with two 3 /4 -inch (19 mm) bolts, or the equivalent.

(3) Except as provided in paragraph (b)(4) of this section, each steel joist shall be attached to the support structure, at least at one end on both sides of the seat, immediately upon placement in the final erection position and before additional joists are placed.

(4) Panels that have been pre-assembled from steel joists with bridging shall be attached to the structure at each corner before the hoisting cables are released.

**(c) Erection of steel joists.**

(1) Both sides of the seat of one end of each steel joist that requires bridging under Tables A and B shall be attached to the support structure before hoisting cables are released.

(2) For joists over 60 feet, both ends of the joist shall be attached as specified in paragraph (b) of this section and the provisions of paragraph (d) of this section met before the hoisting cables are released.

(3) On steel joists that do not require erection bridging under Tables A and B, only one employee shall be allowed on the joist until all bridging is installed and anchored.

▶ **NOTE: TABLES A and B HAVE BEEN EDITED TO CONFORM WITH STEEL JOIST INSTITUTE BOLTED DIAGONAL BRIDGING REQUIREMENTS. EDITED ITEMS ARE SHOWN WITH A STRIKE THROUGH NOTATION. NEW ITEMS ARE SHOWN IN PINK.**

▶ **TABLE A. — ERECTION BRIDGING FOR SHORT SPAN JOISTS**

Joist	Span
<del>8L4</del> 8K1	NM
10K1	NM
12K1	23-0
12K3	NM
12K5	NM
14K1	27-0
14K3	NM
14K4	NM
14K6	NM
16K2	29-0
16K3	30-0
16K4	32-0
16K5	32-0
16K6	NM
16K7	NM
16K9	NM
18K3	31-0
18K4	32-0
18K5	33-0
18K6	35-0
18K7	NM
18K9	NM
18K10	NM
20K3	32-0
20K4	34-0
20K5	34-0
20K6	36-0
20K7	39-0
20K9	39-0
20K10	NM
22K4	34-0
22K5	35-0
22K6	36-0
22K7	40-0
22K9	40-0
22K10	<del>40-0</del> NM
22K11	<del>40-0</del> NM
24K4	36-0
24K5	38-0
24K6	39-0
24K7	43-0
24K8	43-0
24K9	44-0
24K10	NM
24K12	NM
26K5	38-0
26K6	39-0

NM = diagonal bolted bridging not mandatory for joists under 40 feet.



► **TABLE A. — ERECTION BRIDGING FOR SHORT SPAN JOISTS (continued)**

Joist	Span
26K7	43-0
26K8	44-0
26K9	<del>45-0</del> 44-0
26K10	49-0
26K12	NM
28K6	40-0
28K7	43-0
28K8	44-0
28K9	45-0
28K10	49-0
28K12	53-0
30K7	44-0
30K8	45-0
30K9	45-0
30K10	50-0
30K11	52-0
30K12	54-0
10KCS1	NM
10KCS2	NM
10KCS3	NM
12KCS1	NM
12KCS2	NM
12KCS3	NM
14KCS1	NM
14KCS2	NM
14KCS3	NM
16KCS2	NM
16KCS3	NM
16KCS4	NM
16KCS5	NM
18KCS2	35-0
18KCS3	NM
18KCS4	NM
18KCS5	NM
20KCS2	36-0
20KCS3	39-0
20KCS4	NM
20KCS5	NM
22KCS2	36-0
22KCS3	40-0
22KCS4	NM
22KCS5	NM
24KCS2	39-0
24KCS3	44-0
24KCS4	NM
24KCS5	NM
26KCS2	39-0
26KCS3	44-0
26KCS4	NM
26KCS5	NM
28KCS2	40-0
28KCS3	45-0
28KCS4	53-0
28KCS5	53-0
<del>30KCS3</del> 30KCS3	45-0
30KCS4	54-0
30KCS5	54-0

NM = diagonal bolted bridging not mandatory for joists under 40 feet.

► **TABLE B. — ERECTION BRIDGING FOR LONG SPAN JOISTS**

Joist	Span
18LH02	33-0
18LH03	NM.
18LH04	NM.
18LH05	NM.
18LH06	NM.
18LH07	NM.
18LH08	NM.
18LH09	NM.
20LH02	33-0
20LH03	38-0
20LH04	NM.
20LH05	NM.
20LH06	NM.
20LH07	NM.
20LH08	NM.
20LH09	NM.
20LH10	NM.
24LH03	35-0
24LH04	39-0
24LH05	40-0
24LH06	45-0
24LH07	NM.
24LH08	NM.
24LH09	NM.
24LH10	NM.
24LH11	NM.
28LH05	42-0
28LH06	<del>42-0</del> 46-0
28LH07	<del>NM.</del> 54-0
28LH08	<del>NM.</del> 54-0
28LH09	NM.
28LH10	NM.
28LH11	NM.
28LH12	NM.
28LH13	NM.
32LH06	47-0 through 60-0
32LH07	47-0 through 60-0
32LH08	55-0 through 60-0
32LH09	NM through 60-0
32LH10	NM through 60-0
32LH11	NM through 60-0
32LH12	NM through 60-0
32LH13	NM through 60-0
32LH14	NM through 60-0
32LH15	NM through 60-0
36LH07	47-0 through 60-0
36LH08	47-0 through 60-0
36LH09	57-0 through 60-0
36LH10	NM through 60-0
36LH11	NM through 60-0
36LH12	NM through 60-0
36LH13	NM through 60-0
36LH14	NM through 60-0
36LH15	NM through 60-0
40LH08	47-0 through 59-0
40LH09	47-0 through 59-0
44LH09	52-0 through 59-0

NM = diagonal bolted bridging not mandatory for joists under 40 feet.



(4) Employees shall not be allowed on steel joists where the span of the steel joist is equal to or greater than the span shown in Tables A and B except in accordance with § 1926.757(d).

(5) When permanent bridging terminus points cannot be used during erection, additional temporary bridging terminus points are required to provide stability. (See appendix C of this subpart.)

**(d) Erection bridging.**

(1) Where the span of the steel joist is equal to or greater than the span shown in Tables A and B, the following shall apply:

- (i) A row of bolted diagonal erection bridging shall be installed near the midspan of the steel joist;
- (ii) Hoisting cables shall not be released until this bolted diagonal erection bridging is installed and anchored; and
- (iii) No more than one employee shall be allowed on these spans until all other bridging is installed and anchored.

(2) Where the span of the steel joist is over 60 feet (18.3 m) through 100 feet (30.5 m), the following shall apply:

- (i) All rows of bridging shall be bolted diagonal bridging;
- (ii) Two rows of bolted diagonal erection bridging shall be installed near the third points of the steel joist;
- (iii) Hoisting cables shall not be released until this bolted diagonal erection bridging is installed and anchored; and
- (iv) No more than two employees shall be allowed on these spans until all other bridging is installed and anchored.

(3) Where the span of the steel joist is over 100 feet (30.5 m) through 144 feet (43.9 m), the following shall apply:

- (i) All rows of bridging shall be bolted diagonal bridging;
- (ii) Hoisting cables shall not be released until all bridging is installed and anchored; and
- (iii) No more than two employees shall be allowed on these spans until all bridging is installed and anchored.

(4) For steel members spanning over 144 feet (43.9 m), the erection methods used shall be in accordance with § 1926.756.

(5) Where any steel joist specified in paragraphs (c)(2) and (d)(1), (d)(2), and (d)(3) of this section is a bottom chord bearing joist, a row of bolted diagonal bridging shall be provided near the support(s). This bridging shall be installed and anchored before the hoisting cable(s) is released.

(6) When bolted diagonal erection bridging is required by this section, the following shall apply:

- (i) The bridging shall be indicated on the erection drawing;
- (ii) The erection drawing shall be the exclusive indicator of the proper placement of this bridging;
- (iii) Shop-installed bridging clips, or functional equivalents, shall be used where the bridging bolts to the steel joists;
- (iv) When two pieces of bridging are attached to the steel joist by a common bolt, the nut that secures the first piece of bridging shall not be removed from the bolt for the attachment of the second; and
- (v) Bridging attachments shall not protrude above the top chord of the steel joist.

**(e) Landing and placing loads.**

(1) During the construction period, the employer placing a load on steel joists shall ensure that the load is distributed so as not to exceed the carrying capacity of any steel joist.

(2) Except for paragraph (e)(4) of this section, no construction loads are allowed on the steel joists until all bridging is installed and anchored and all joist-bearing ends are attached.

(3) The weight of a bundle of joist bridging shall not exceed a total of 1,000 pounds (454 kg). A bundle of joist bridging shall be placed on a minimum of three steel joists that are secured at one end. The edge of the bridging bundle shall be positioned within 1 foot (0.30 m) of the secured end.

(4) No bundle of decking may be placed on steel joists until all bridging has been installed and anchored and all joist bearing ends attached, unless all of the following conditions are met:

- (i) The employer has first determined from a qualified person and documented in a site-specific erection plan that the structure or portion of the structure is capable of supporting the load;
- (ii) The bundle of decking is placed on a minimum of three steel joists;
- (iii) The joists supporting the bundle of decking are attached at both ends;
- (iv) At least one row of bridging is installed and anchored;
- (v) The total weight of the bundle of decking does not exceed 4,000 pounds (1816 kg); and
- (vi) Placement of the bundle of decking shall be in accordance with paragraph (e)(5) of this section.

(5) The edge of the construction load shall be placed within 1 foot (0.30 m) of the bearing surface of the joist end.



# ILLUSTRATIONS OF OSHA BRIDGING TERMINUS POINTS (NON-MANDATORY)

Guidelines for Complying with OSHA Steel Erection Standard, Paragraph §1926.757(a)(10) and §1926.757(c)(5).

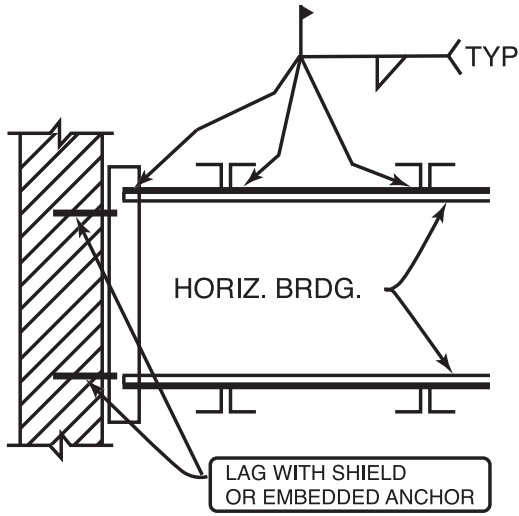

HORIZONTAL BRIDGING TERMINUS AT WALL

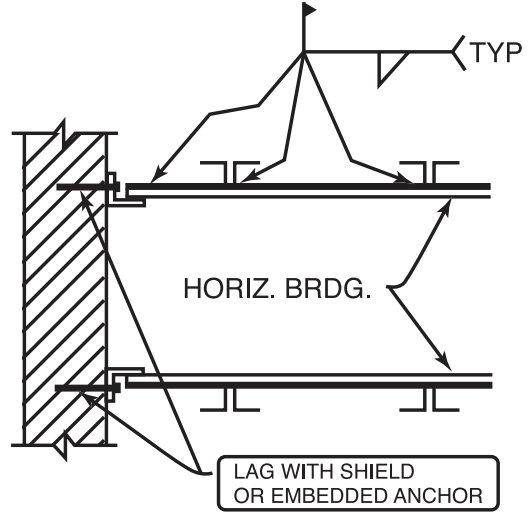

HORIZONTAL BRIDGING TERMINUS AT WALL

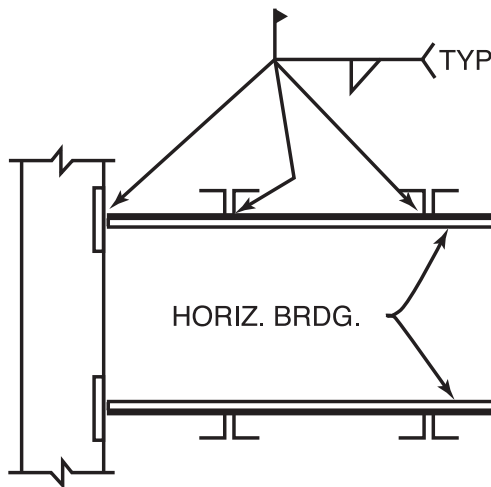

HORIZONTAL BRIDGING TERMINUS AT PANEL WALL

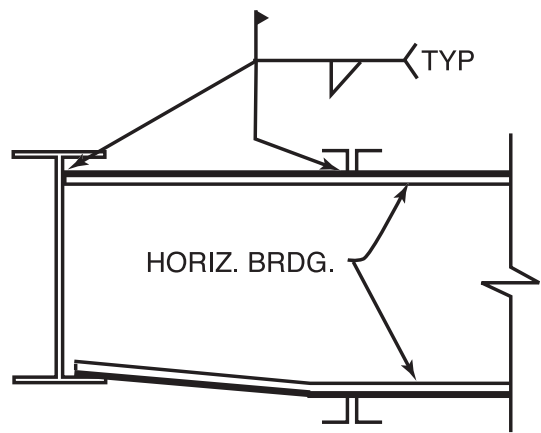

HORIZONTAL BRIDGING TERMINUS AT STRUCTURAL SHAPE



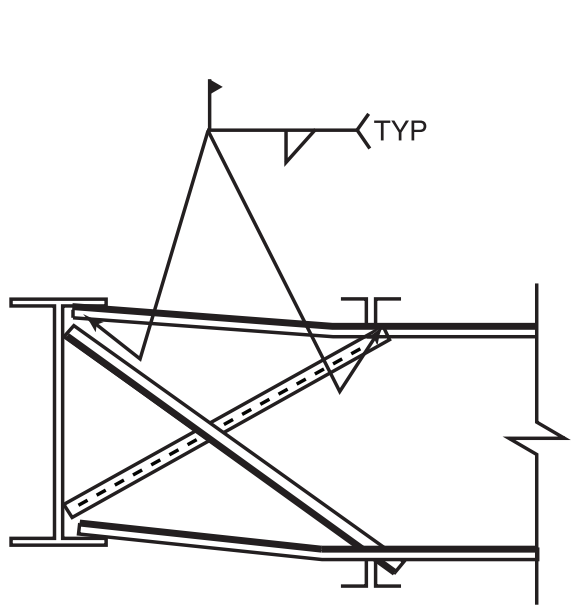

HORIZONTAL BRIDGING  
TERMINUS AT STRUCTURAL  
SHAPE WITH OPTIONAL  
"X-BRIDGING"

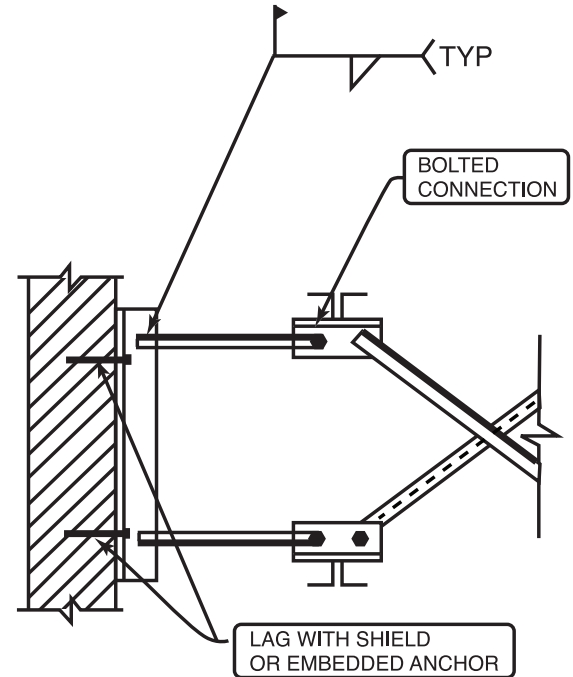

BOLTED DIAGONAL BRIDGING  
TERMINUS AT WALL

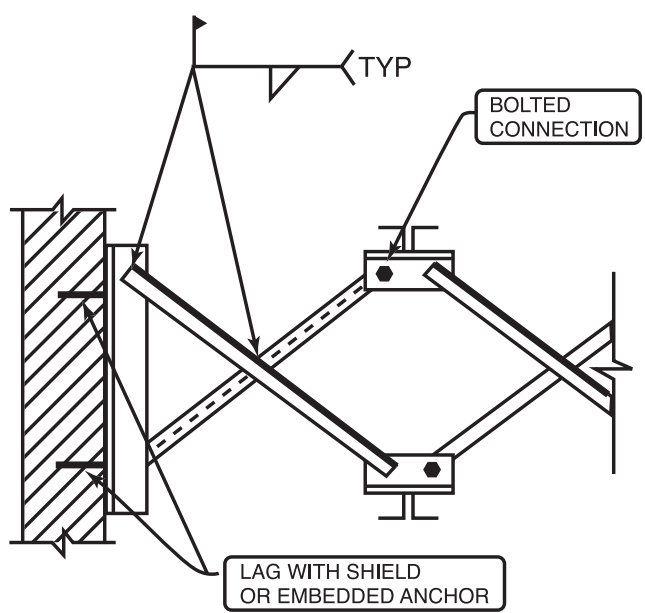

BOLTED DIAGONAL BRIDGING  
TERMINUS AT WALL

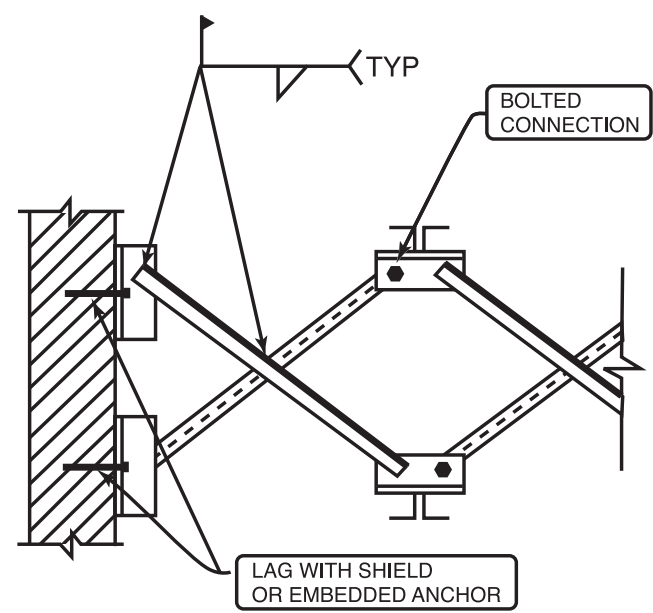

BOLTED DIAGONAL BRIDGING  
TERMINUS AT WALL





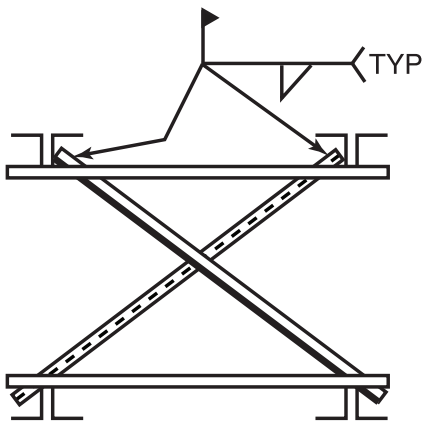

JOISTS PAIR BRIDGING  
TERMINUS POINT

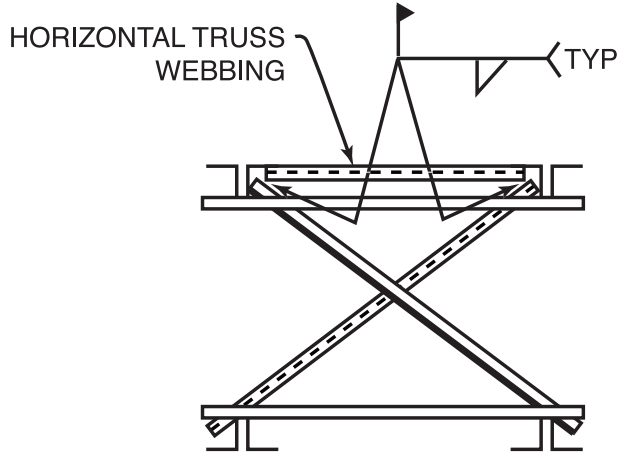

JOISTS PAIR BRIDGING  
TERMINUS POINT

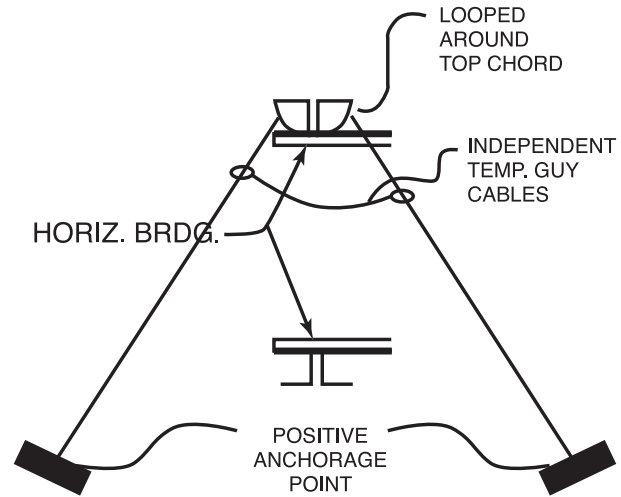

HORIZONTAL BRIDGING  
TERMINUS POINT  
SECURED BY TEMP.  
GUY CABLES

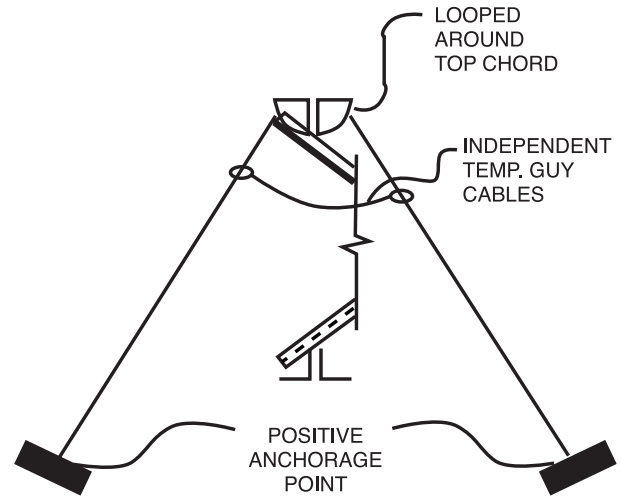

DIAGONAL BRIDGING  
TERMINUS POINT  
SECURED BY TEMP.  
GUY CABLES

